

# Sunuprise Technology Ltd.

## 10/100/1000Base SMD Transformer

PartNumber: SG24002

Page:1/1

- Compliant with IEEE 802.3 standard,
- RoHS compliant.
- Operating temperature range :0°C to +70°C.
- Storage temperature range:-25°C to +125°C

### Electrical Specifications @ 25°C

Part Number	Turns Ratio (±5%)		OCL(uH Min) @100KHz/0.1V with 8.0mA DC	Insertion Loss (dB Max) 1-100MHz	HI-POT (Vrms) 1500
	TX	RX			
SG24002	1CT:1CT	1CT:1CT	350	-1.1	1500

### Continue

Part Number	Return Loss (dB Min)					Cross Talk (dB Min)			DCMR (dB Min)		
	1-30MHz	40MHz	50MHz	60-80MHz	100MHz	30MHz	60MHz	80MHz	30MHz	60MHz	100MHz
SG24002	-18	-14.4	-13.1	-12	-10	-45	-40	-35	-43	-37	-33

### Schematics:

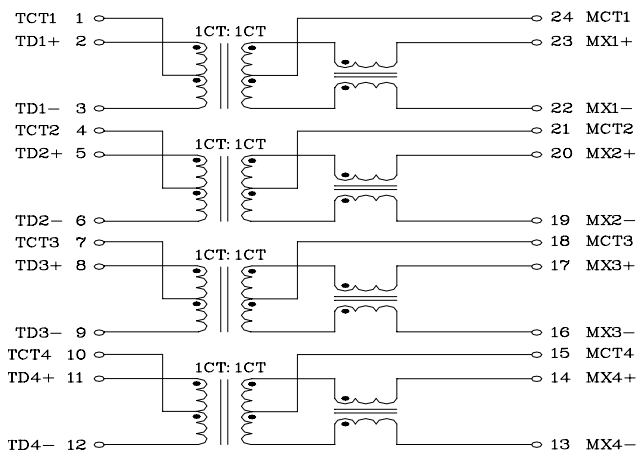

### Mechanicals:

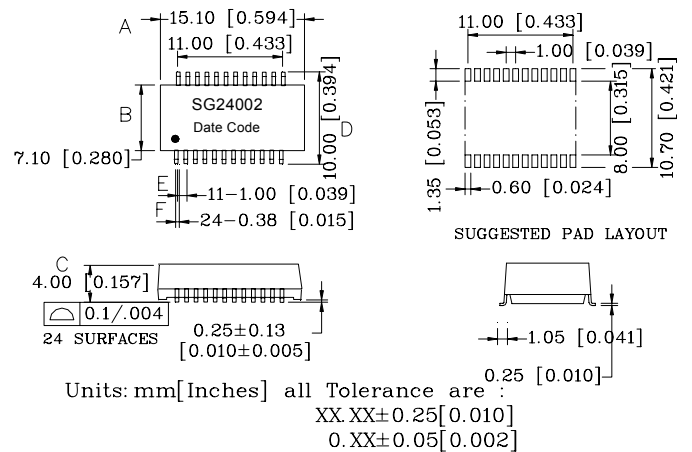

R0(07/12)

Tel: +86-816-5019526/0-15908202442 E-mail: Johnhubei@163.com